

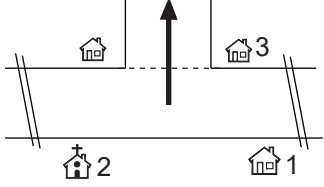

NOTA	PARCIAIS	TOTAIS	DIREÇÃO	OBSERVAÇÕES
1	0,000	0,000		1 - Câmara Municipal 2 - Igreja 3 - Café Havanesa DESCE RUA PRINCIPAL EM EMPEDRADO
2	0,100	0,100		DIR. PORTO/COIMBRA POUCO DEPOIS SEGUE ASFALTO PRINCIPAL
3	0,500	0,600		CONTINUA ASFALTO PRINCIPAL POUSADA DA JUVENTUDE
4	0,200	0,800		DIR. GUARDA POSTO DE TURISMO
5	0,400	1,200		1 - Monumento DIR. HOSPITAL ENTRA EMPEDRADO
6	0,400	1,600		DIR. GUARDA DESCE AVENIDA
7	0,300	1,900		NA ROTUNDA REGRESSA E SOBE AVENIDA QUE DESCEU
8	0,200	2,100		1 - GALP DIR. MUSEU DO CÔA SEGUE AVENIDA

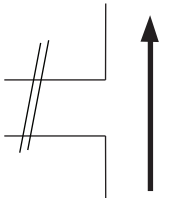

NOTA	PARCIAIS	TOTAIS	DIREÇÃO	OBSERVAÇÕES
1	0,200	2,300		CONTINUA AVENIDA
2	0,200	2,500		1 - Centro de saúde DIR. MUSEU DO CÔA
3	0,100	2,600		JÁ EM EMPEDRADO DIR. MUSEU POUCO DEPOIS ASFALTO
4	0,200	2,800		ENTRA E SEGUE EMPEDRADO ENTRE MUROS MUSEU
5	0,700 0,000	3,500 0,000		1 - Parque de merendas do Salgueiro ENTRA TERRA PÔR KM A ZERO
6	0,300	0,300		SEGUE P.P. DIR. CAMINHO DO CERRO DA PEREIRA
7	0,400	0,700		SEGUE P.P.
8	0,100	0,800		

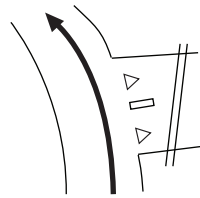
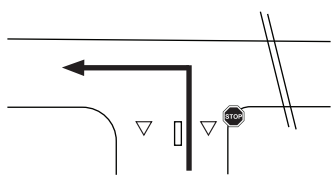
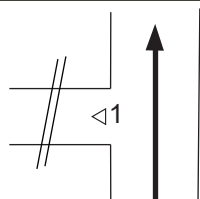
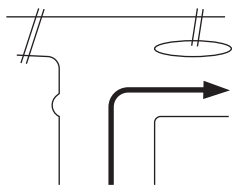
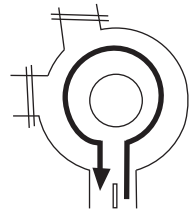
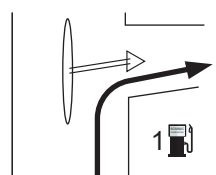
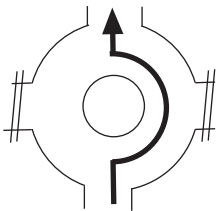
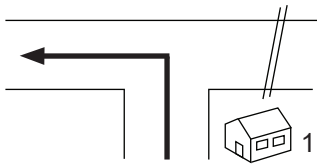
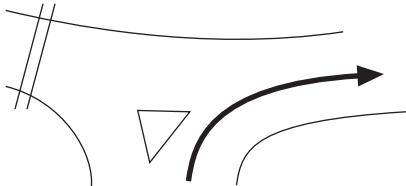
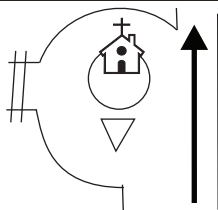
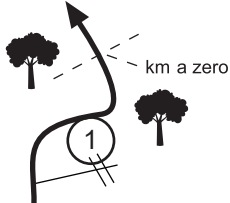
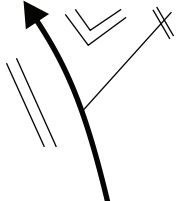
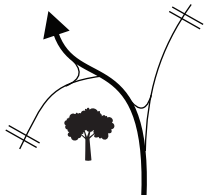
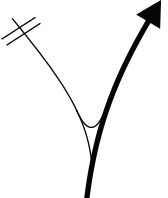
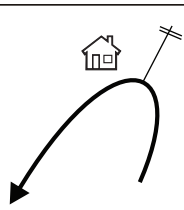
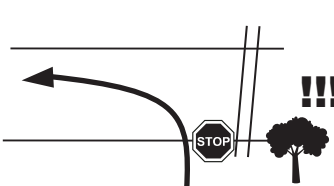
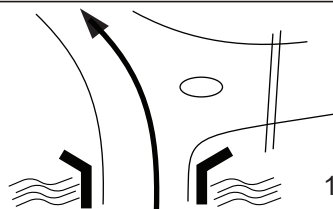
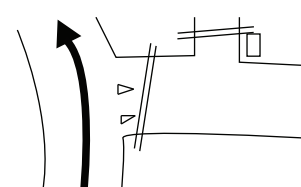
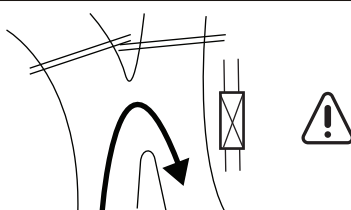
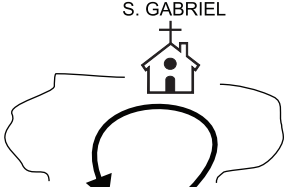
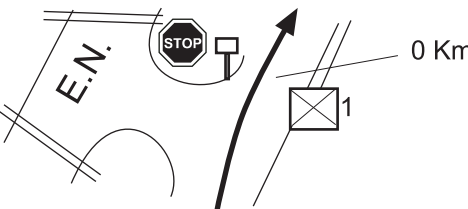
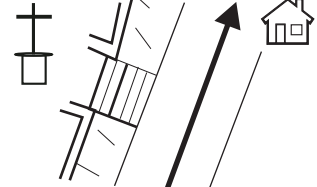
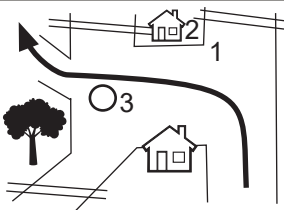
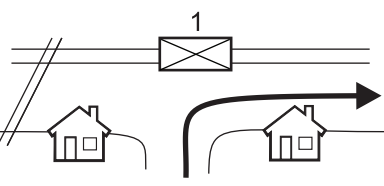
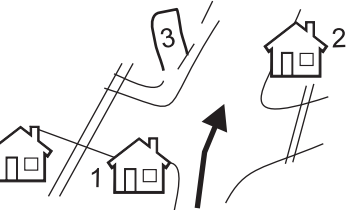
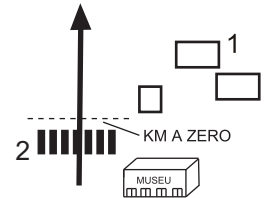
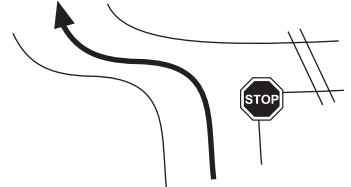
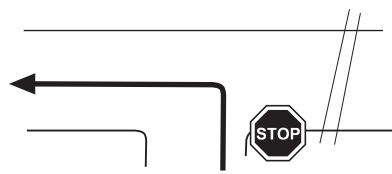
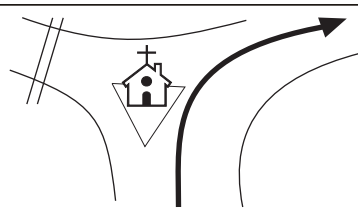
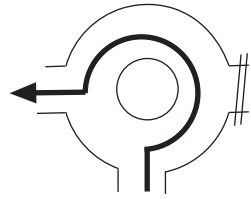
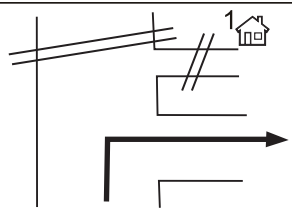
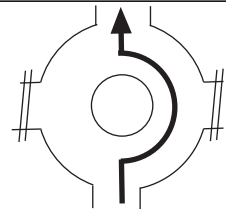
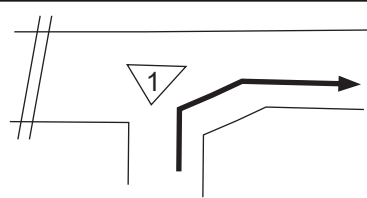

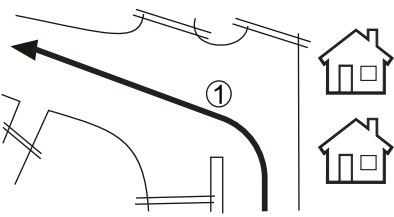
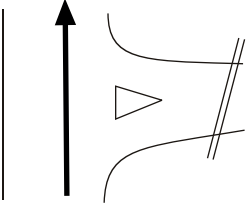
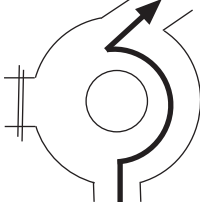
NOTA	PARCIAIS	TOTAIS	DIREÇÃO	OBSERVAÇÕES
1	0,300	1,100		DESCE
2	1,700	2,800		ENTRA ASFALTO EN222 ATT!!! STOP
3	0,300	3,100		1 - Rio Côa CONTINUA EN222
4	3,500	6,600		CONTINUA EN222 ORGAL
5	3,600	10,200		DEIXA EN222 SOBE EMPEDRADO DIR. S. GABRIEL
6	1,200	11,400		ADMIRE PAISAGEM E REGRESSE PELO EMPEDRADO QUASE ATÉ AO ASFALTO
7	1,200 0,000	12,600 0,000		1- Portão vermelho CONTINUA EMPEDRADO PÔR KM A ZERO
8	0,800	0,800		CASTELO MELHOR

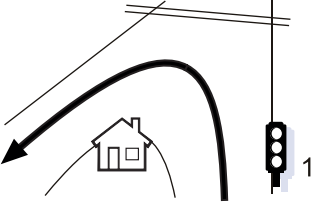
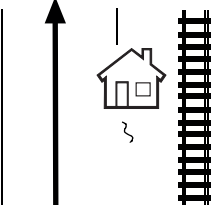
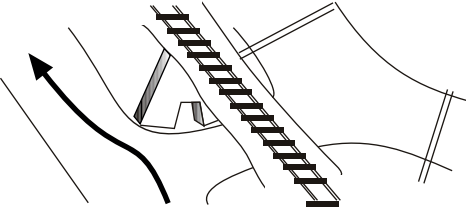
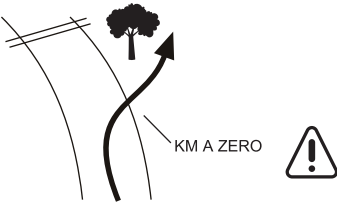

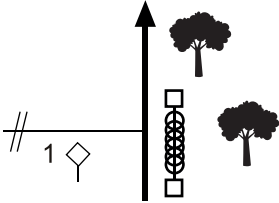
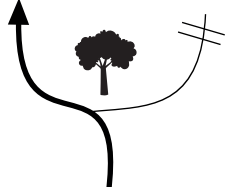
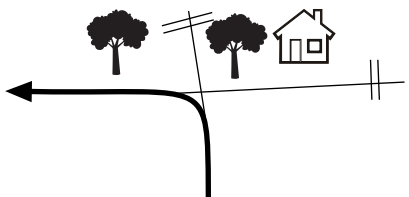
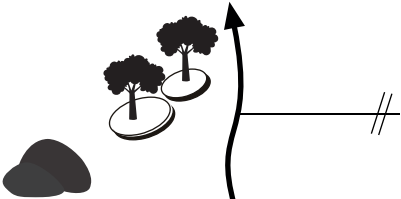
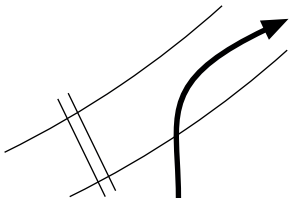
NOTA	PARCIAIS	TOTAIS	DIREÇÃO	OBSERVAÇÕES
1	0,200	1,000		1 - Espelho 2 - Casa nº 10 3 - Rotunda DESCE
2	0,100	1,100		1 - Portão branco
3	0,100	1,200		1- Sede de Freguesia 2- portão verde 3- Placa Parque Arqueológico CENTRO DE RECEÇÃO VISITE

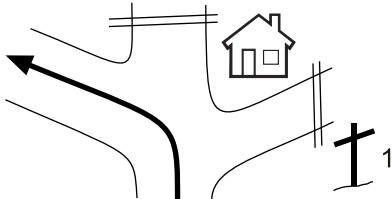
NOTA	PARCIAIS	TOTAIS	DIREÇÃO	OBSERVAÇÕES
1	0,000 /	0,000 /		1 - Placas informativas 2 - Passadeira MUSEU DO CÔA PÔR KM A ZERO
2	1,900	1,900		ATT!!! STOP
3	0,200	2,100		ATT!!! STOP DIR. CENTRO
4	0,100	2,200		SOBE
5	0,300	2,500		DESCE E ENTRA ASFALTO
6	0,100	2,600		1 - Centro de saúde - Urgências SOBE AVENIDA
7	0,100	2,700		
8	0,200	2,900		1 - Quiosque ATT!! STOP ENTRA AVENIDA ENTRA EMPEDRADO

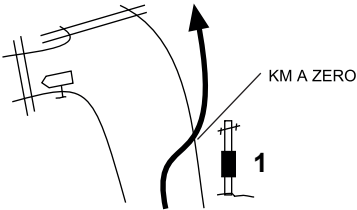
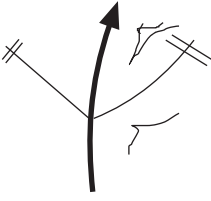
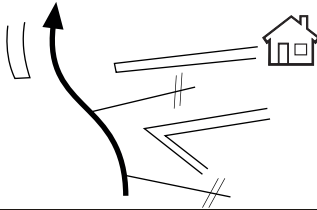
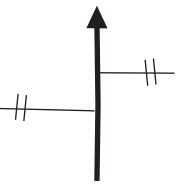
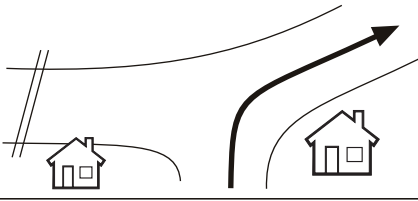
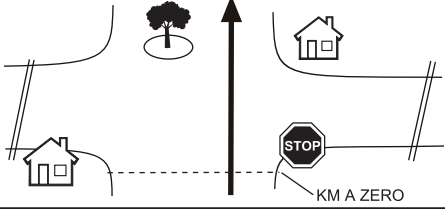
NOTA	PARCIAIS	TOTAIS	DIREÇÃO	OBSERVAÇÕES
1	0,100	3,000		1 - Monumento DIR. BRAGANÇA/ MONCORVO SEGUE EMPEDRADO PRINCIPAL
2	0,700	3,700		JÁ EM ASFALTO ESTÁDIO SEGUE EN102
3	5,400	9,100		DIR. BRAGANÇA MACEDO DE CAVALEIROS
4	0,100	9,200		
5	0,400	9,600		1 - Semáforos DIR. SANTO AMARO MÓS
6	0,200	9,800		ENTRA EMPEDRADO ESTAÇÃO DO POCINHO POUSO DEPOIS ASFALTO
7	0,900	10,700		DIR. MÓS SANTO AMARO
8	0,100 0,000	10,800 0,000		PÔR KM A ZERO ENTRA E SOBE EMPEDRADO DIR. CAPELA E MIRADOURO POUCO DEPOIS TERRA SEGUE P.P.

NOTA	PARCIAIS	TOTAIS	DIREÇÃO	OBSERVAÇÕES
1	0,900	0,900		1- Placa Zona de caça SOBE P.P. AVISTA RIO DOURO E BARRAGEM DO POCINHO
2	0,200	1,100		ATT!! NESTE TROÇO ATÉ ASFALTO, OS 4X2 DEVEM MANTER VELOCIDADE E TRAÇÃO
3	0,300	1,400		QUINTA DO CERCÃO SOBE P.P.
4	1,000	2,400		SOBE E SEGUE P.P. ADMIRE PAISAGEM
5	2,000	4,400		ENTRA E SOBE ASFALTO
6	0,900	5,300		
7	0,400	5,700		DIR. FREIXO DE NUMÃO
8	0,200	5,900		1- Cruzeiro SOBE EMPEDRADO POUCO DEPOIS ASFALTO ESTREITO DIR. FREIXO DE NUMÃO

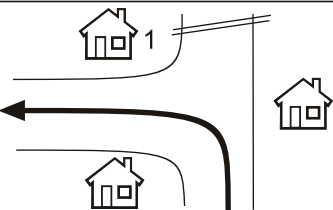
NOTA	PARCIAIS	TOTAIS	DIREÇÃO	OBSERVAÇÕES
1	4,100 /	10,000 /		1 - Poste 41 tapado com placa de caça PÔR KM A ZERO ENTRA TERRA
2	0,300	0,300		DESCE P.P.
3	0,700	1,000		CONTINUA P.P.
4	0,400	1,400		DESCE P.P. ATÉ POVOAÇÃO
5	0,400	1,800		JÁ EM EMPEDRADO ENTRA ASFALTO FREIXO DE NUMÃO
6	0,200 /	2,000 /		ATT!!! STOP PÔR KM A ZERO
7	0,100	0,100		1- S. João Baptista SOBE EMPEDRADO
8	0,200	0,300		DIR. PRAZO

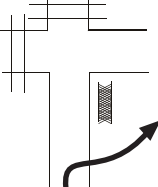
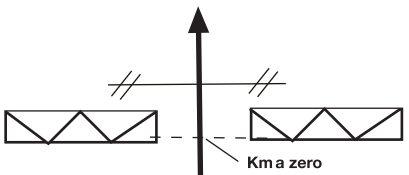
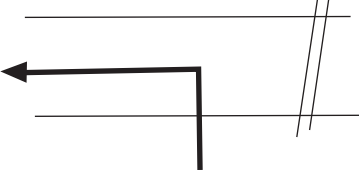
NOTA	PARCIAIS	TOTAIS	DIREÇÃO	OBSERVAÇÕES
1	0,050	0,350		1- Portão verde DIR. PRAZO
2	0,050	0,400		DIR. PRAZO SEGUE SEMPRE EMPEDRADO
3	2,100	2,500		DEIXA P.P. ENTRA RUÍNAS DO PRAZO VISITE
4	0,200 0,000	2,700 0,000		PÔR KM A ZERO SAI RUÍNAS DO PRAZO SEGUE SEMPRE EMPEDRADO DIR. TOUÇA
5	2,000	2,000		ATT!!! STOP ENTRA E SEGUE ASFALTO EN222 NO PRÓXIMO CRUZAMENTO PODE SEGUIR PARA FOZ CÔA OU MÊDA